

YASKAWA

MOTOMAN MPL160-100 II

Palletising with the MPL-series

The versatile and powerful 4-axis MOTOMAN MPL160-100 II robot provides high performance in box palletising, case palletising and many further logistical tasks for end-of-line or distribution center automation.



Its extensive vertical reach of 3024 mm combined with 3159 mm horizontal reach enables high palletising loads. Empty tubes for internally routed airlines and cables from base to end-of-arm tool maximize system reliability.

The MPL160-100 II features extremely high acceleration which reduces cycle times.

The MPL160-100 II is driven by the high-performance DX200 controller which is available with the optional Category 3 Functional Safety Unit (FSU), providing a variety of new safety functions.

KEY BENEFITS

- Compact, flexible and powerful
- High acceleration and speed:
Up to 1800 cycles/h palletizing capa, suitable for box palletising
- High Payload: 100 kg
- Large motion range:
 - 2624 mm square reach (on pallet 1300 x 1300 mm)
 - 2363 mm stack height (on pallet 1600 x 1600 mm)
- Maximum reliability, empty tubes for internally routed airlines and cables
- Internally routed fieldbus connection (optional) to T-axis/tool
- Enhanced Safety Functions for DX200 Functional Safety Controller (FSU)
- Protection class IP54/67

Controlled by
DX200

MOTOMAN MPL160-100 II

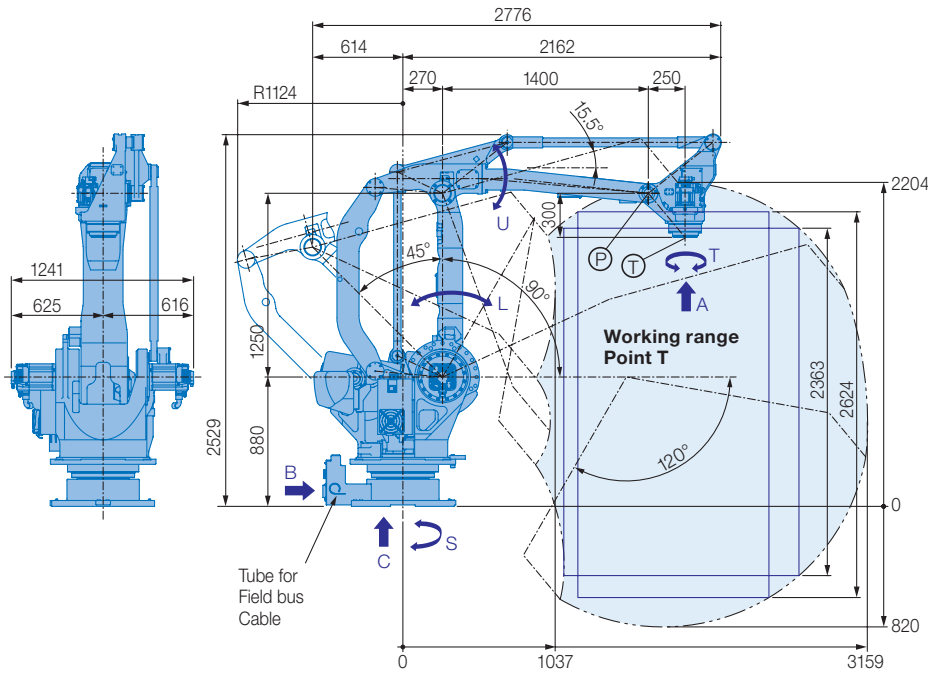

View A

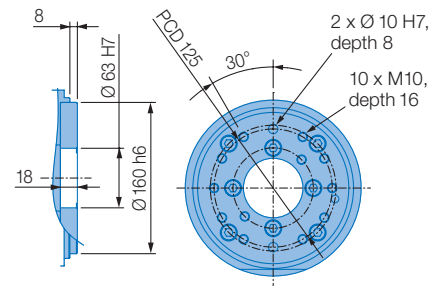

View B

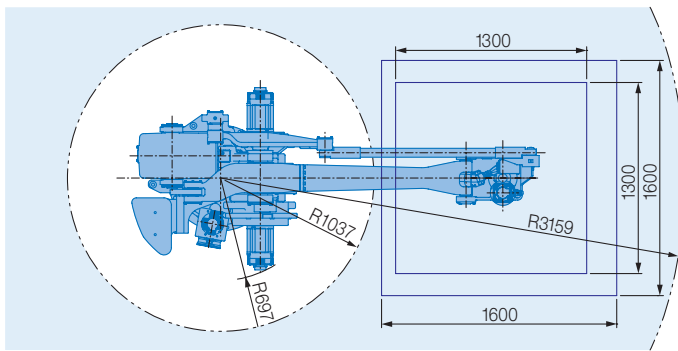
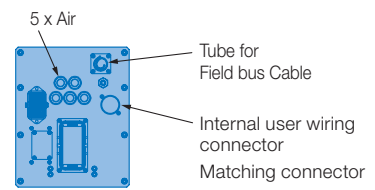

View C

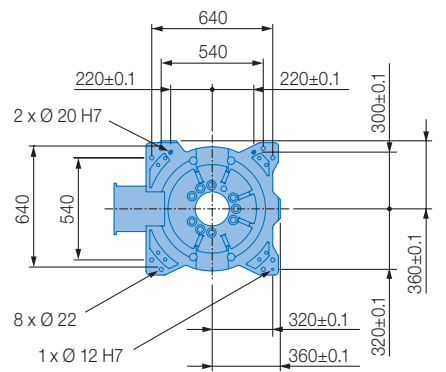

Mounting option: Floor
Protection class: IP54/67

All dimensions in mm | Technical data may be subject to change without previous notice | Please request detailed drawings at robotics@yaskawa.eu - YR-MPL160-100-J00, A-06-2016, A-No. 179120

Allowable wrist load

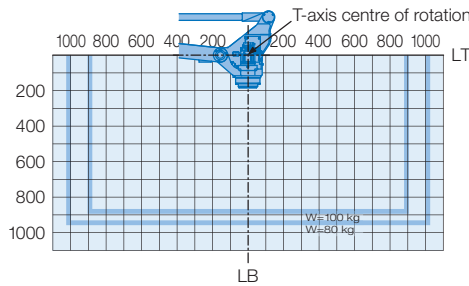

Specifications MPL160-100 II

Axes	Maximum motion range [°]	Maximum speed [°/sec.]	Allowable moment [Nm]	Allowable moment of inertia [kg · m ²]	Controlled axes	
					Max. payload [kg]	
S	±180	140	-	-	Repeat. pos. accuracy [mm]	±0.5
L	+90/-45	140	-	-	Max. working range R [mm]	3159
U	+15.5/-120	140	-	-	Temperature [°C]	0 to +45
R	-	-	-	-	Humidity [%]	20 - 80
B	-	-	-	-	Weight [kg]	1700
T	±360	305	-	80	Power supply, average [KVA]	9.5

YASKAWA

robotics@yaskawa.eu
www.yaskawa.eu

YASKAWA Headquarters

YASKAWA Europe GmbH · Robotics Division
Yaskawastraße 1 · D-85391 Allershausen
Tel. +49 (0) 8166/90-0 · Fax +49 (0) 8166/90-103

YASKAWA ACADEMY and sales office Frankfurt

YASKAWA Europe GmbH · Robotics Division
Hauptstraße 185 · D-65760 Eschborn
Tel. +49 (0) 6196/77725-0 · Fax +49 (0) 6196/77725-39