

YASKAWA

MOTOMAN GP88

Handling & General Applications
with the GP-series



The MOTOMAN GP88 is a versatile high speed 6-axis robot, providing a high payload of up to 88 kg. It offers superior performance in material handling, machine tending, processing and dispensing applications.

Despite its slim body, the MOTOMAN GP88 features a wide work envelope with a small interference radius. Thereby it can be placed close to machines for loading and unloading of parts, which reduces the required floor space to a minimum.

KEY BENEFITS

- Flexible and powerful (payload of 88 kg)
- High axis speeds
- Improved wrist ratings provide higher handling capacity
- Small interference radius reduces floor space requirements

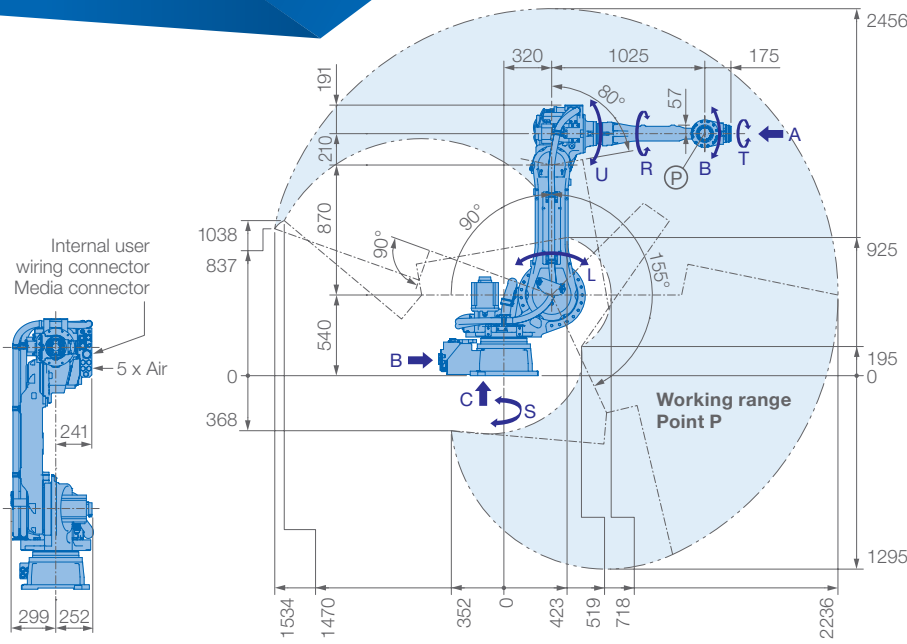

View A

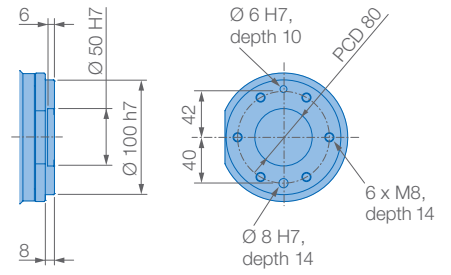

View B

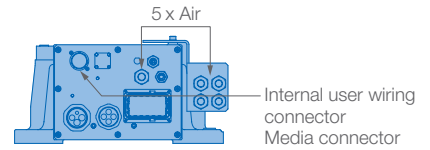

View C

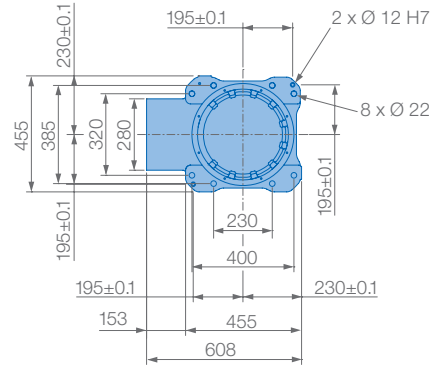

Mounting options: Floor, ceiling, wall, tilt*

Protection class: IP54/67
Please notice: Just valid for body/wrist, connector base not protected

* tilt with condition of angle – see table left side

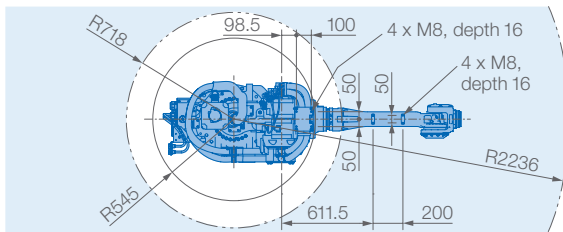

Allowable wrist load

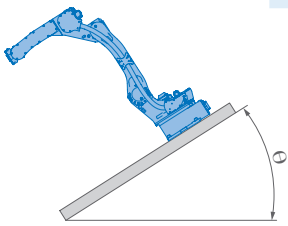
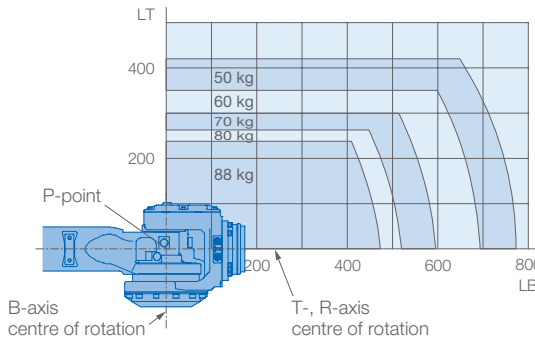

Robot installation angle θ [deg.]	S-axis operating range [deg.]
$0 \leq \theta \leq 30$	± 180 (Standard)
$30 < \theta \leq 35$	± 60
$35 < \theta \leq 45$	± 45
$45 < \theta$	± 45

Specifications GP88					
Axes	Maximum motion range [°]	Maximum speed [°/sec.]	Allowable moment [Nm]	Allowable moment of inertia [kg · m ²]	Controlled axes
S	± 180	170	–	–	6
L	+155/–90	140	–	–	Max. payload [kg]
U	+90/–80	160	–	–	88
R	± 360	230	408	30	Repeatability [mm]
B	± 125	230	408	30	± 0.07
T	± 360	350	206	11	Max. working range R [mm]
					2236
					Temperature [°C]
					0 to +45
					Humidity [%]
					20 – 80
					Weight [kg]
					630
					Power supply, average [KVA]
					4.0

YASKAWA Europe GmbH

Robotics Division
 Yaskawastraße 1
 85391 Allershausen
 Germany

Tel. +49 (0) 8166 90-0
 robotics@yaskawa.eu.com
 www.yaskawa.eu.com

YR-1-06VX88-A00
 A-06-2018, A-No. 195936

All dimensions in mm. Technical data may be subject to change without previous notice.
 Please request detailed drawings at robotics@yaskawa.eu.com.