

SJDE-□APA-OY

# Junma Pulse servo drive

**A new concept in drive simplicity  
Save space, save time**

- Ultra compact drive size reduces panel space
- Tuning-less technology, no gain parameters need to be set
- Peak torque 300% of nominal for 3 seconds
- High response, high speed, high torque and high accuracy
- Fully "Parameter-less" just plug and run
- Position resolution of 10,000 steps per revolution

**Ratings**

- 230 VAC Single-phase 100 W to 750 W (2.39 Nm)



AC Servo systems

## System Configuration

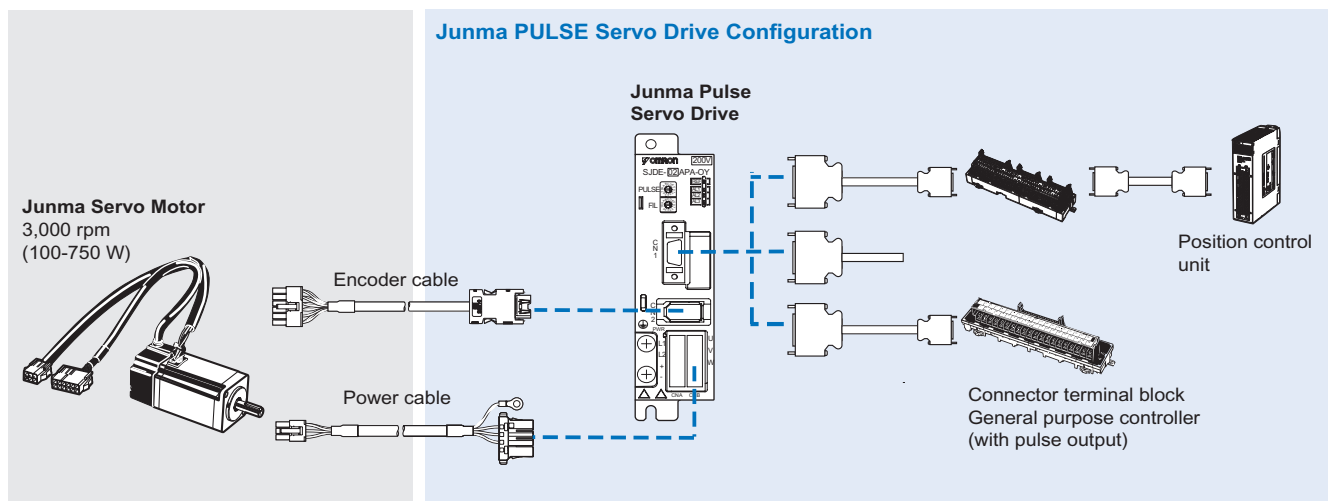

## Servomotor / Servo Drive Combination

Junma Servomotor	Voltage	Rated Torque	Capacity	Model without brake	Model with brake	Junma servo drive
SJME- (3000 min <sup>-1</sup> ) 	200 V	0.318 Nm	100 W	SJME-01AMB41-OY	SJME-01AMB4C-OY	SJDE-01APA-OY
		0.637 Nm	200 W	SJME-02AMB41-OY	SJME-02AMB4C-OY	SJDE-02APA-OY
		1.27 Nm	400 W	SJME-04AMB41-OY	SJME-04AMB4C-OY	SJDE-04APA-OY
		2.39 Nm	750 W	SJME-08AMB41-OY	SJME-08AMB4C-OY	SJDE-08APA-OY

## Servo Drive Type Designation

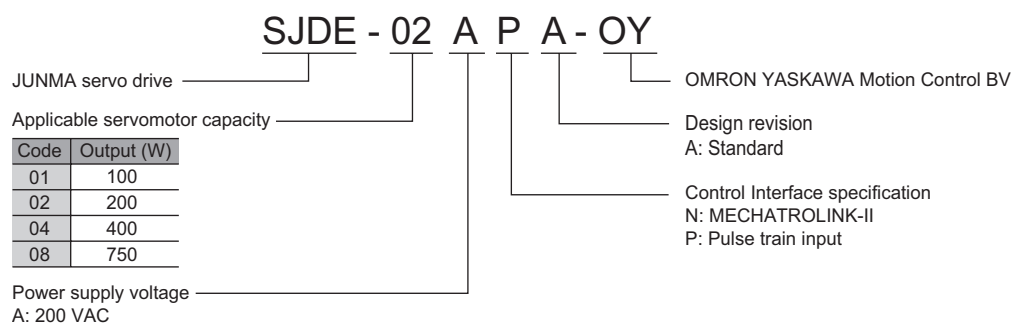

Servo Drive Specifications

Junma Pulse Servo Drives

Servo Drive Type	SJDE-□	01APA-OY	02APA-OY	04APA-OY	08APA-OY	
Applicable servomotor	SJME-□	01A□	02A□	04A□	08A□	
Basic specifications	Max. Applicable Motor capacity	W	100	200	400	750
	Continuous output current	Arms	0.84	1.1	2.0	3.7
	Max. output current	Arms	2.5	3.3	6.0	11.1
	Input power supply (Main circuit and control circuit)	Voltage	Single-phase, 200 to 230 VAC, + 10 to -15% (50/60 Hz)			
		Capacity KVA	0.40	0.75	1.2	2.2
	Control Method	PWM control, sine wave current drive system				
	Feedback	Analogue incremental encoder (10000 steps per revolution)				
	Allowable load inertia <sup>1</sup>	kg·m <sup>2</sup>	0.6 × 10 <sup>-4</sup>	3.0 × 10 <sup>-4</sup>	5.0 × 10 <sup>-4</sup>	10.0 × 10 <sup>-4</sup>
	Usage / storage temperature	0 to +55° C / -20 to 70° C				
	Usage / storage humidity	90%RH or less (non-condensing)				
Altitude	1000 m or less above sea level					
Vibration/shock Resistance	4.9m/s <sup>2</sup> (0.5G) / 19.6m/s <sup>2</sup> (2G)					
Configuration	Base mounted					
Cooling method	Forced cooling (built-in fan)					
Approx. mass	kg	0.5			1.0	
Built-in functions	Dynamic brake (DB)	Operated at main power OFF, servo alarm, servo OFF.(OFF after motor stops; ON when motor power is off.)				
	Regenerative processing	Optional (If the regenerated energy is too large, install a regenerative unit JUSP-RG08D)				
	LED display	5 (PWE, REF, AL1, AL2, AL3)				
	Reference filter	Select one of eight levels with FIL switch				
	Protection	Speed errors, overload, encoder errors, voltage errors, overcurrents, disablement of the built-in cooling fan, system errors				
I/O Signals	Input signal for reference Designated pulse type and pulse resolution with PULSE switch.	Pulse type	Select one of the following signals: 1. CCW + CW 2. Sign + pulse train 3. CCW + CW (logic reversal) 4. Sign + pulse train (logic reversal)			
		Pulse resolution	Select one of the following signals: 1. 1000 pulses/rev (Open collector/line driver) 75 kpps max. 2. 2500 pulses/rev (Open collector/line driver) 187.5 kpps max. 3. 5000 pulses/rev (Line driver) 375 kpps max. 4. 10000 pulses/rev (Line driver) 750 kpps max.			
	Clear input signal	Clears the positioning error when turned ON				
	Servo ON input signal	Turns the servomotor ON or OFF				
	Alarm output signal	OFF if an alarm occurs. (Note: OFF for 2s when power is turned ON)				
	Brake output signal	External signal to control brakes. Turn ON to release the brake				
	Positioning completed output signal	ON if the current position is equal to the reference position ±10 pulses.External signal to control brakes.				
Origin output signal	ON if the motor is at the origin. (Width: 1/500 rev) (Note:Use the pulse edge that changes the signal from OFF to ON)					

Note: \*1. Value without external regeneration unit

Dimensions

Junma pulse control servo drives

SJDE-01, 02APA-OY (200V, 100 to 200W)

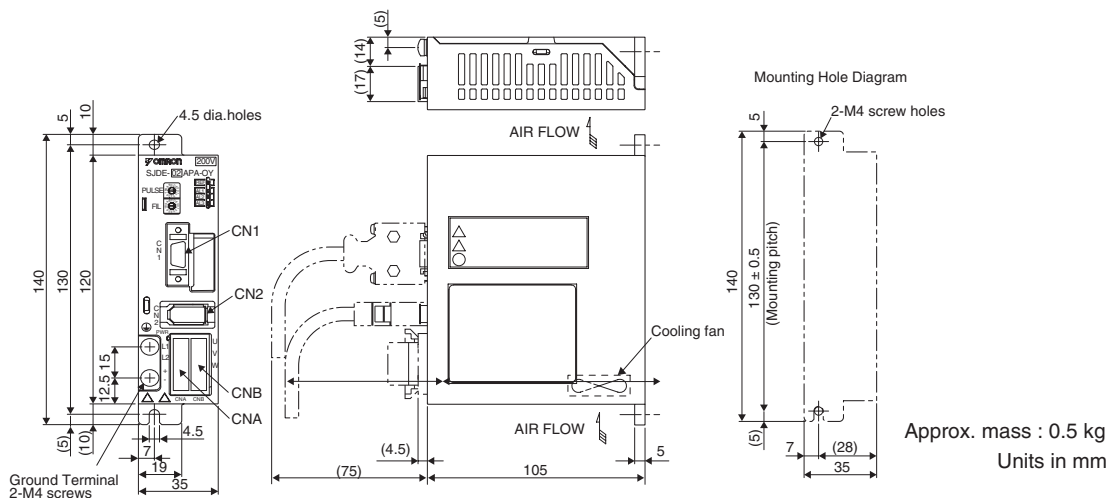

**SJDE-04APA-OY (200V, 400W)**

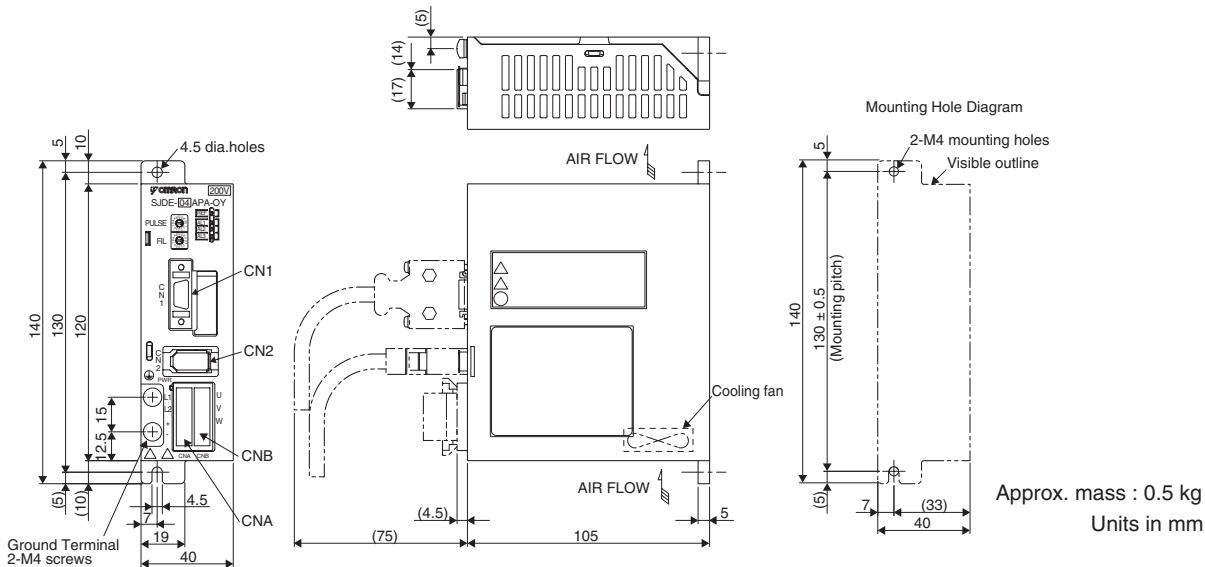

**SJDE-08APA-OY (200V, 800W)**

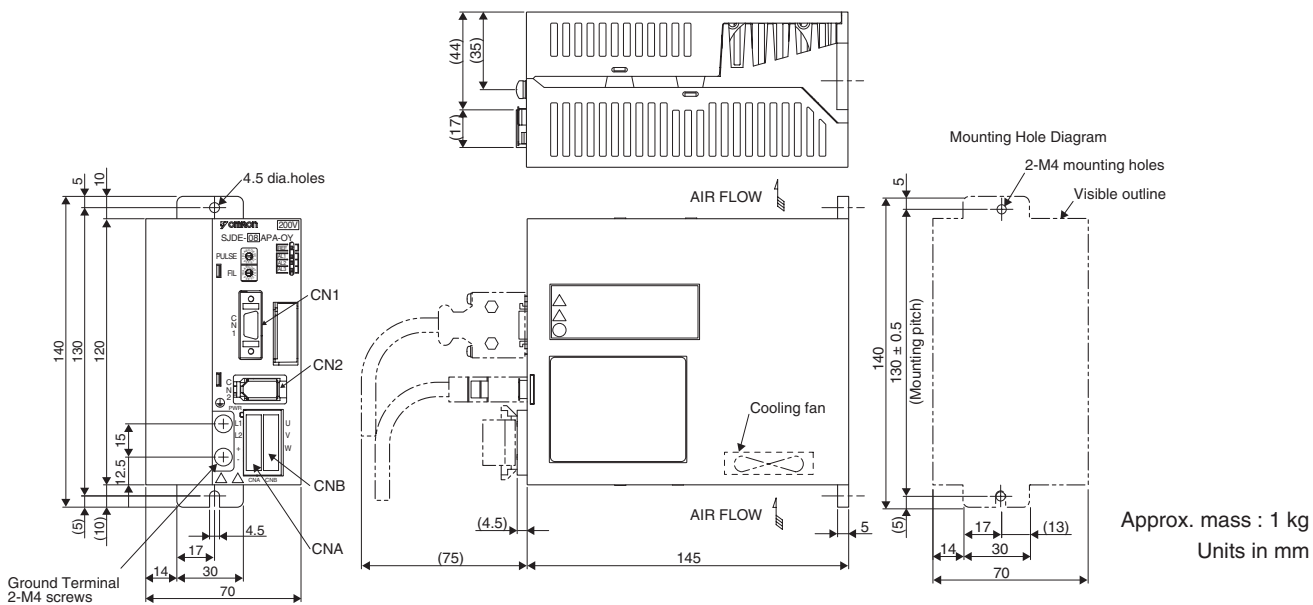

**Ordering Information**

**Junma Pulse Servo Drive Configuration**

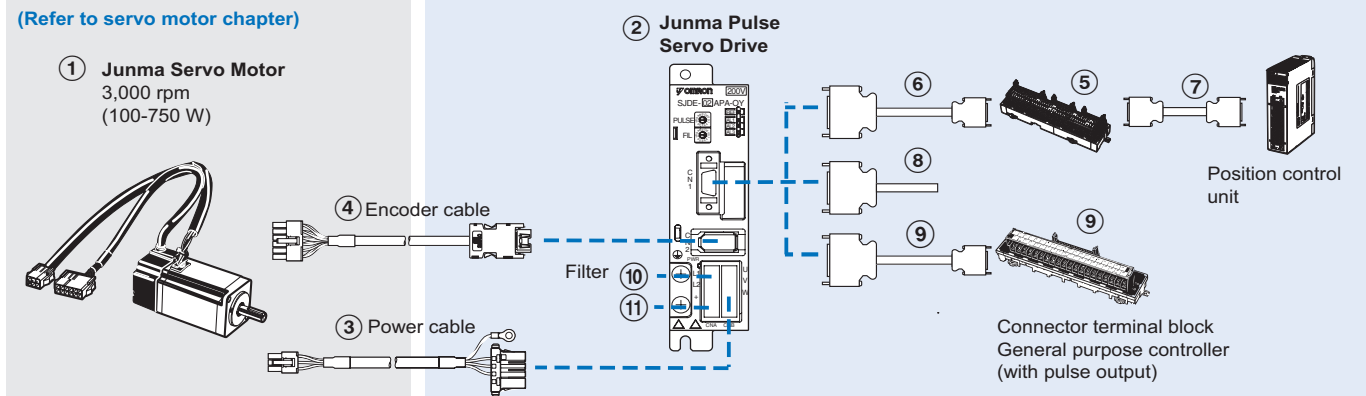

Servomotors and Servo drives

Symbol	Specifications				① Servomotor model	② Servo drive model	
	Voltage	Encoder and Design	Rated Torque	Capacity			
①②	1 Phase 200 VAC	Analogue Incremental Encoder  Straight shaft with key	Without brake	0.318 Nm	100 W	SJME-01AMB41-OY	SJDE-01APA-OY
				0.637 Nm	200 W	SJME-02AMB41-OY	SJDE-02APA-OY
				1.27 Nm	400 W	SJME-04AMB41-OY	SJDE-04APA-OY
				2.39 Nm	750 W	SJME-08AMB41-OY	SJDE-08APA-OY
			With brake	0.318 Nm	100 W	SJME-01AMB4C-OY	SJDE-01APA-OY
				0.637 Nm	200 W	SJME-02AMB4C-OY	SJDE-02APA-OY
				1.27 Nm	400 W	SJME-04AMB4C-OY	SJDE-04APA-OY
				2.39 Nm	750 W	SJME-08AMB4C-OY	SJDE-08APA-OY

Control cables (for CN1)

Symbol	Name	Compatible units	Model		
⑤	Servo relay unit	Units: CS1W-NC113/133, CJ1W-NC113/133, C200HW-NC113	- XW2B-20J6-1B (1 axis)		
		Units: CS1W-NC213/233/413/433, CJ1W-NC213/233/413/433, C200HW-NC213/413	- XW2B-40J6-2B (2 axes)		
		Units: CQM1H-PLB21 and CQM1-CPU43-V1	- XW2B-20J6-3B (1 axis)		
		Use with CJ1M-CPU21/22/23	- XW2B-20J6-8A (1 axis) - XW2B-40J6-9A (2 axes)		
⑥	Cable to servo drive	For the servo relay unit XW2B-□□J6-□□B, XW2B-20J6-8A, XW2B-40J6-9A	1 m XW2Z-100J-B17		
			2 m XW2Z-200J-B17		
⑦	Cable to position control unit	CQM1H-PLB21 and CQM1-CPU43-V1	0.5 m XW2Z-050J-A3 1 m XW2Z-100J-A3		
		CS1W-NC113 and C200HW-NC113	0.5 m XW2Z-050J-A8 1 m XW2Z-100J-A8		
		CS1W-NC213/413 and C200HW-NC213/413	0.5 m XW2Z-050J-A9 1 m XW2Z-100J-A9		
		CS1W-NC133	0.5 m XW2Z-050J-A12 1 m XW2Z-100J-A12		
		CS1W-NC233/433	0.5 m XW2Z-050J-A13 1 m XW2Z-100J-A13		
		CJ1W-NC113	0.5 m XW2Z-050J-A16 1 m XW2Z-100J-A16		
		CJ1W-NC213/413	0.5 m XW2Z-050J-A17 1 m XW2Z-100J-A17		
		CJ1W-NC133	0.5 m XW2Z-050J-A20 1 m XW2Z-100J-A20		
		CS1W-NC233/433	0.5 m XW2Z-050J-A21 1 m XW2Z-100J-A21		
		CJ1M-CPU21/22/23	0.5 m XW2Z-050J-A26 1 m XW2Z-100J-A26		
		⑧	Control cable	For general-purpose controllers	1 m R7A-CPZ001S or JZSP-CHI003-01
					2 m R7A-CPZ002S or JZSP-CHI003-02
					3 m JZSP-CHI003-03
		⑨	Connector terminal block cable	For general-purpose controllers	1 m XW2Z-100J-B19
					2 m XW2Z-200J-B19
			Connector terminal block		- XW2B-20G5

Filters

Symbol	Applicable servo drive	Rated current	Leakage current	Rated voltage	Filter model
⑩	SJDE-01APA-OY	5A	1.7 mA	250 VAC 1- phase	R7A-FIZP105-BE
	SJDE-02APA-OY				
	SJDE-04APA-OY				
	SJDE-08APA-OY	9A	1.7 mA		R7A-FIZP109-BE

Regenerative Unit Model (Option)

Symbol	Specifications	Model (Omron)	Model (Yaskawa)
⑪	External regenerative unit (Optional)	R88A-RG08UA	JUSP-RG08D

Connectors

Specification	Model (Omron)	Model (Yaskawa)
Control I/O connector (for CN1)	R7A-CNA01R	JZSP-CHI9-1
Power input connector (for CNB). (Included in drive the box)	R7A-CNZ01P	JZSP-CHG9-1

Power and encoder cables

Note: ③④ Refer to the Junma servo motor section for motor cables or connectors selection

ALL DIMENSIONS SHOWN ARE IN MILLIMETERS.  
To convert millimeters into inches, multiply by 0.03937. To convert grams into ounces, multiply by 0.03527.