

SJDE-□ANA-OY

# Junma ML-II servo drive

**A new concept in drive simplicity  
Save space, save wiring, save time**

- Ultra compact drive size reduces panel space
- Tuning-less technology, no gain parameters need to be set
- Peak torque 300% of nominal for 3 seconds
- High response, high speed, high torque and high accuracy
- Drive version with MECHATROLINK-II port built-in
- MECHATROLINK-II simplifies wiring and reduces installation time
- MECHATROLINK-II provides access to the system from one point



AC Servo systems

## Ratings

- 230 VAC Single-phase 100 W to 750 W (2.39 Nm)

## System Configuration

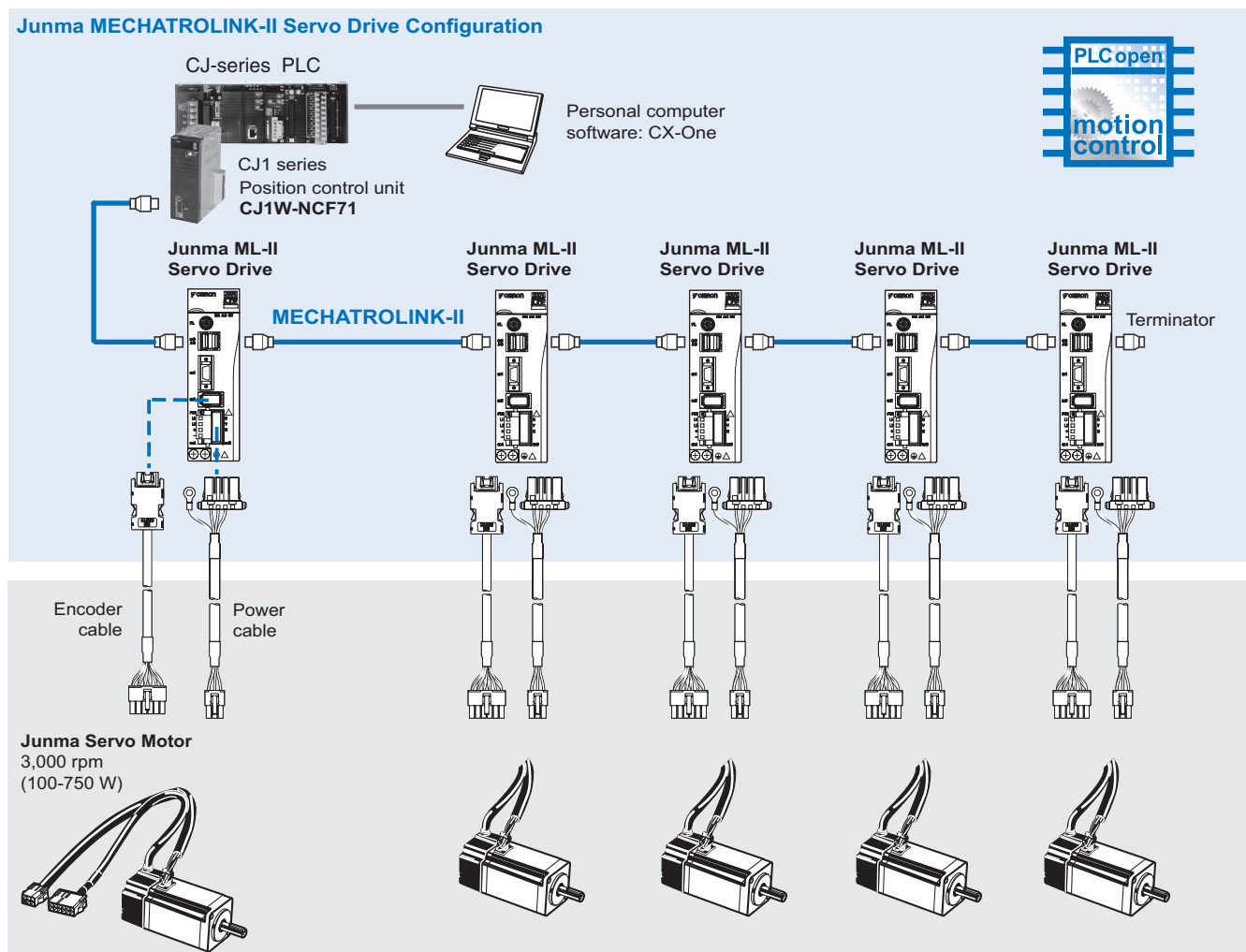

Servomotor / Servo Drive Combination

Junma Servomotor				Junma servo drive		
	Voltage	Rated Torque	Capacity	Model without brake	Model with brake	MECHATROLINK-II
	200 V	0.318 Nm	100 W	SJME-01AMB41-OY	SJME-01AMB4C-OY	SJDE-01ANA-OY
		0.637 Nm	200 W	SJME-02AMB41-OY	SJME-02AMB4C-OY	SJDE-02ANA-OY
		1.27 Nm	400 W	SJME-04AMB41-OY	SJME-04AMB4C-OY	SJDE-04ANA-OY
		2.39 Nm	750 W	SJME-08AMB41-OY	SJME-08AMB4C-OY	SJDE-08ANA-OY

Servo Drive Type Designation

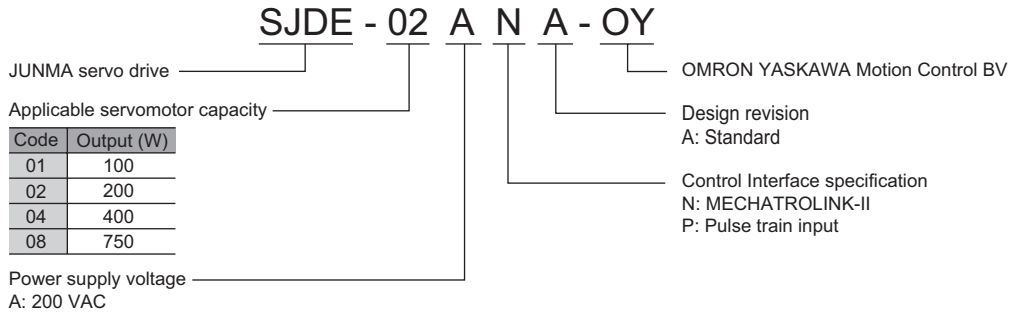

Servo Drive Specifications

Junma MECHATROLINK-II Servo Drive

Servo Drive Type	SJDE-□	01ANA-OY	02ANA-OY	04ANA-OY	08ANA-OY
<b>Applicable servomotor</b>	<b>SJME-□</b>	<b>01A□</b>	<b>02A□</b>	<b>04A□</b>	<b>08A□</b>
Max. Applicable Motor capacity	W	100	200	400	750
Continuous output current	Arms	0.84	1.1	2.0	3.7
Max. output current	Arms	2.5	3.3	6.0	11.1
Input power supply (Main circuit and control circuit)	Voltage	Single-phase, 200 to 230 VAC, + 10 to -15% (50/60 Hz)			
	Capacity KVA	0.40	0.75	1.2	2.2
Control Method	PWM control, sine wave current drive system				
Feedback	Analogue incremental encoder (13 bits incremental equivalent)				
Allowable load inertia <sup>1</sup>	kg·m <sup>2</sup>	0.6 × 10 <sup>-4</sup>	3.0 × 10 <sup>-4</sup>	5.0 × 10 <sup>-4</sup>	10.0 × 10 <sup>-4</sup>
Usage / storage temperature	0 to +55° C / -20 to 70° C				
Usage / storage humidity	90%RH or less (non-condensing)				
Altitude	1000m or less above sea level				
Vibration/shock Resistance	4.9m/s <sup>2</sup> (0.5G) / 19.6m/s <sup>2</sup> (2G)				
Configuration	Base mounted				
Approx. mass	Kg	1.0			1.4
Dynamic brake (DB)	Operated at main power OFF, servo alarm, servo OFF.(OFF after motor stops; ON when motor power is off.)				
Regenerative processing	Optional (If the regenerated energy is too large, install a regenerative unit JUSP-RG08D)				
Over-travel (OT) prevention function	P_OT, N_OT				
Emergency stop	Emergency stop (E-STP)				
LED display	4 LEDs (PWR, RDY, COM, ALM)				
MECHATROLINK-II monitor	MECHATROLINK-II under communication : COM LED (Light ON)				
Servo ON/OFF monitor	At Servo OFF : RDY LED (Light OFF), at Servo ON : RDY LED (Light Blinks)				
Power supply status monitor	Control / main-circuit power-supply OFF state: PWR LED (Light OFF) Control / main-circuit power-supply ON state: PWR LED (Light ON)				
Electronic gearing	0,01 < A/B < 100				
Protection	Overcurrent, overvoltage, undervoltage, overload, main circuit sensor error, board temperature error, excessive position error overflow, overspeed, encoder signal error, overrun protection, system error, parameter error				
MECHATROLINK Communication	Comm. protocol	MECHATROLINK-II			
	Transmission rate	10 Mbps			
	Transmission cycle	1ms, 1.5ms, 2ms, 3ms, 4ms			
	Data length	17 byte and 32 byte			
Command input	MECHATROLINK communication	MECHATROLINK-II commands (For sequence, motion, data setting/reference, monitor, adjustment, and other commands)			
Sequence Input signal	Fixed input	5 points (fixed layout: external latch signal, zero return reduced speed signal, forward drive inhibiting signal, reverse run inhibiting signal, emergency stop signal)			
Sequence Output signal	Fixed output	2 points (fixed layout: servo alarm, brake interlock)			

Note: \*1. Value without external regeneration unit

Dimensions

Junma MECHATROLINK-II servo drives

SJDE-01, 02, 04ANA-OY (200V, 100 to 400W)

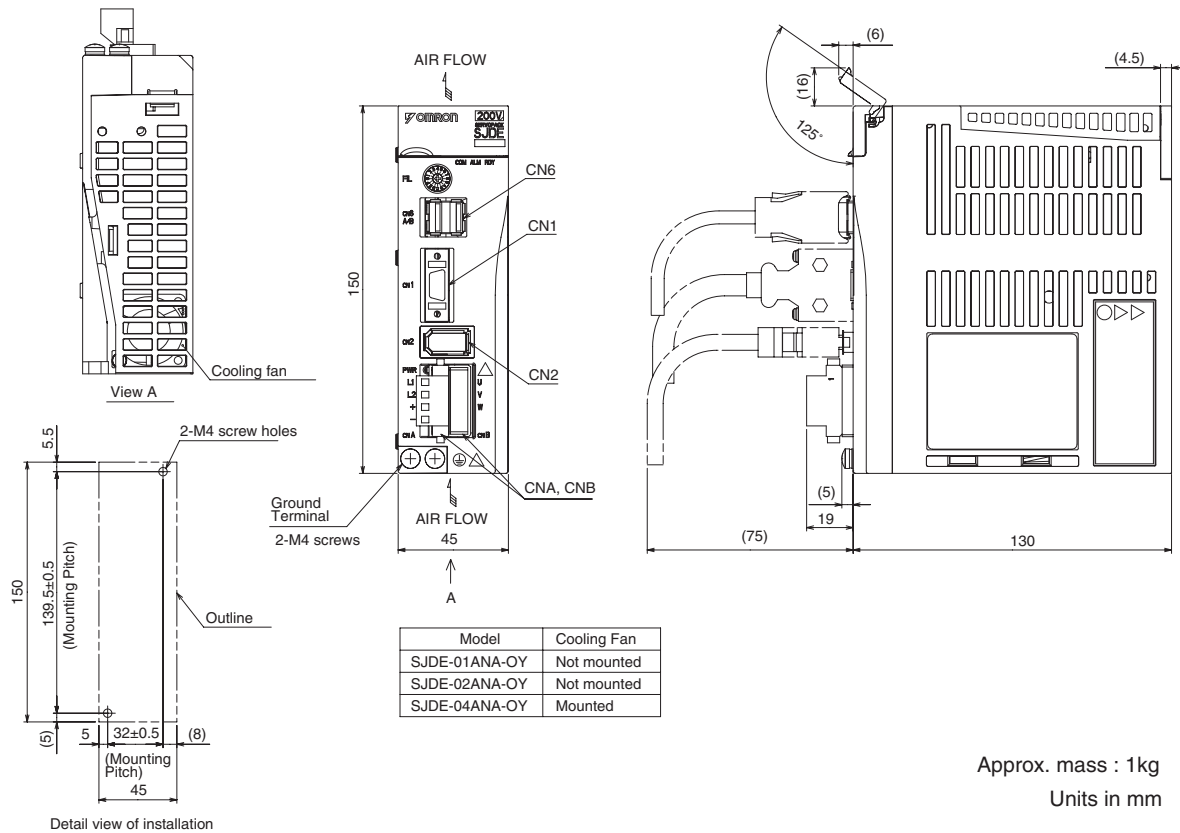

SJDE-08ANA-OY (200V, 750W)

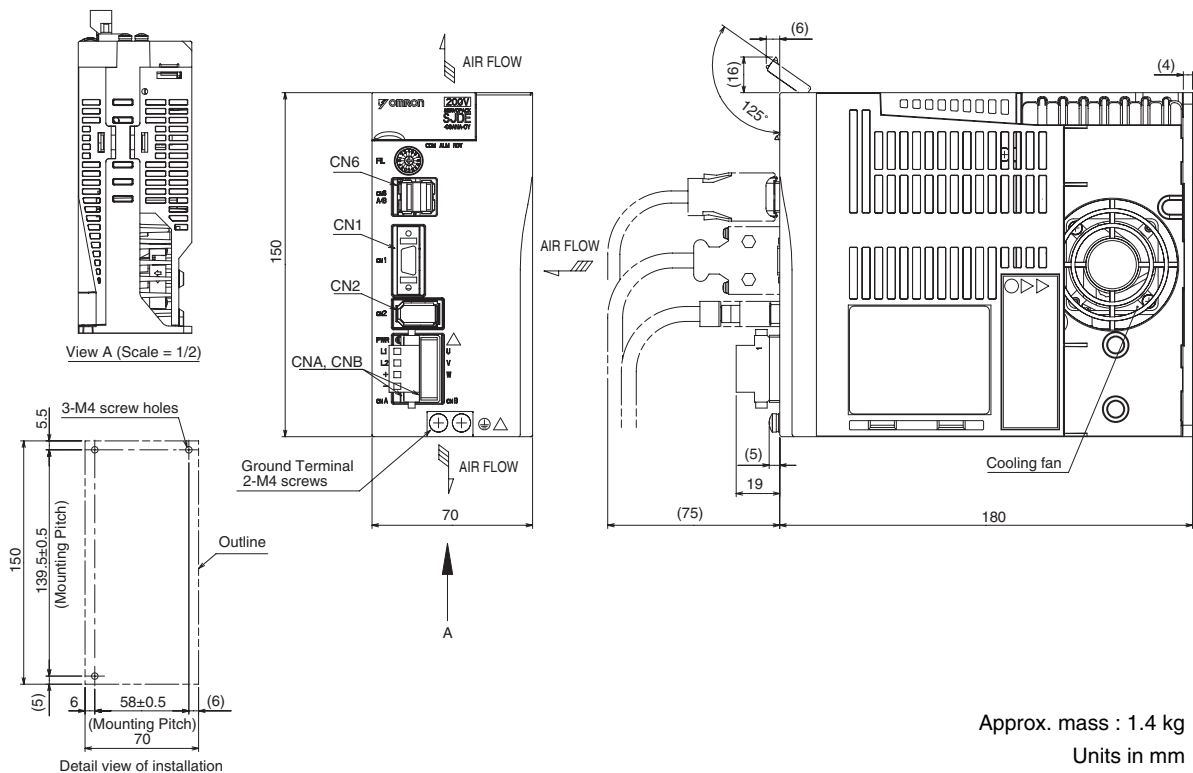

Ordering Information

Junma MECHATROLINK-II Servo Drive Configuration

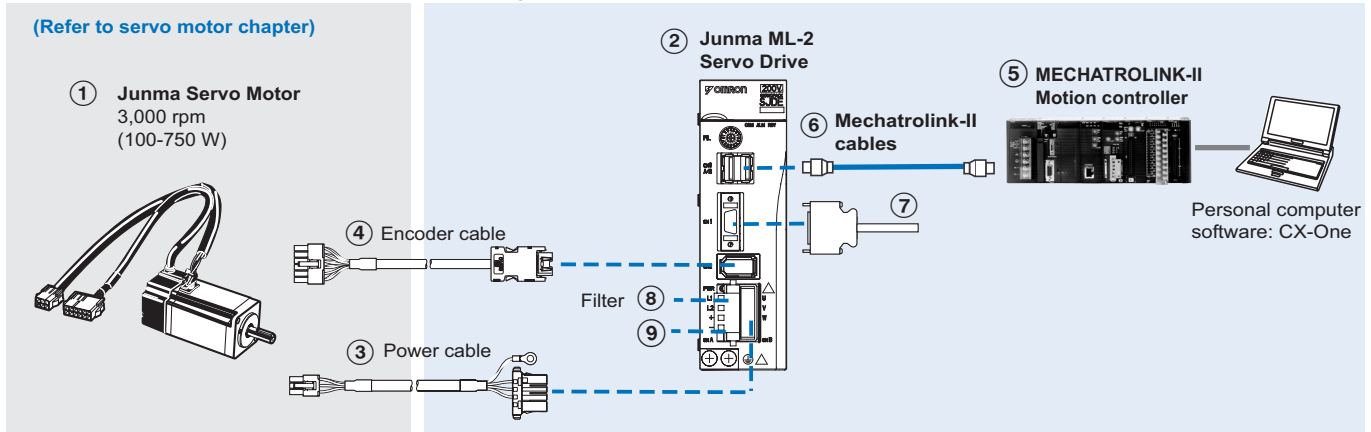

Servomotors and Servo drives

Symbol	Specifications				① Servomotor model	② Servo drive model	
	Voltage	Encoder and Design	Rated Torque	Capacity			
①②	1 Phase 200 VAC	Analogue Incremental Encoder  Straight shaft with key	Without brake	0.318 Nm	100 W	SJME-01AMB41-OY	SJDE-01ANA-OY
				0.637 Nm	200 W	SJME-02AMB41-OY	SJDE-02ANA-OY
				1.27 Nm	400 W	SJME-04AMB41-OY	SJDE-04ANA-OY
				2.39 Nm	750 W	SJME-08AMB41-OY	SJDE-08ANA-OY
		With brake	0.318 Nm	100 W	SJME-01AMB4C-OY	SJDE-01ANA-OY	
			0.637 Nm	200 W	SJME-02AMB4C-OY	SJDE-02ANA-OY	
			1.27 Nm	400 W	SJME-04AMB4C-OY	SJDE-04ANA-OY	
			2.39 Nm	750 W	SJME-08AMB4C-OY	SJDE-08ANA-OY	

Power and encoder cables

Note: ③④ Refer to the Junma servo motor section for motor cables or connectors selection

MECHATROLINK-II Motion controllers

Symbol	Name	Model
⑤	Position Controller Unit for CJ1 PLC	CJ1W-NCF71
	Position Controller Unit for CS1 PLC	CS1W-NCF71
	Trajexia stand-alone motion controller, 16 axes	TJ1-MC16
	Trajexia stand-alone motion controller, 4 axes	TJ1-MC04

Filters

Symbol	Applicable servo drive	Rated current	Leakage current	Rated voltage	Filter model
⑧	SJDE-01ANA-OY	5A	1.7 mA	250 VAC 1-phase	R7A-FIZN105-BE
	SJDE-02ANA-OY				
	SJDE-04ANA-OY				
	SJDE-08ANA-OY				R7A-FIZN109-BE

MECHATROLINK-II cables

Symbol	Specifications	Model	
⑥	MECHATROLINK-II Terminator resistor	JEPMC-W6022	
	MECHATROLINK-II Cables	0.5 m	JEPMC-W6003-A5
		1 m	JEPMC-W6003-01
		3 m	JEPMC-W6003-03
		5 m	JEPMC-W6003-05
		10 m	JEPMC-W6003-10
		20 m	JEPMC-W6003-20
30 m	JEPMC-W6003-30		

Regenerative Unit Model (Option)

Symbol	Specifications	Model (Omron)	Model (Yaskawa)
⑨	External regenerative unit (Optional)	R88A-RG08UA	JUSP-RG08D

Connectors

Specification	Model (Omron)	Model (Yaskawa)
Control I/O connector (for CN1)	R7A-CNA01R	JZSP-CHI9-1
Power input connector (for CNB). (Included in drive the box)	R7A-CNZ01P	JZSP-CHG9-1

Cables for I/Os (for CN1)

Symbol	Name	Compatible units	Model	
⑦	Control cable	Cable for servo drive I/O signals	1 m	R7A-CPZ001S or JZSP-CHI003-01
			2 m	R7A-CPZ002S or JZSP-CHI003-02
			3 m	JZSP-CHI003-03

Computer Software

Specifications	Model
Configuration and monitoring software tool via ML2 (CX-Drive version 1.3 or higher)	CX-DRIVE
Complete Omron software package including CX-Drive (CX-One 2.0 or higher)	CX-ONE

ALL DIMENSIONS SHOWN ARE IN MILLIMETERS.  
To convert millimeters into inches, multiply by 0.03937. To convert grams into ounces, multiply by 0.03527.